



EMC TEST REPORT

For
ROOF FANS

Model No. : DVR 280T, DVR 315T, DVR 355T, DVR 400T, DVR 450T, DVR 500T,
DVR 560T, DVR 630T, DVR 710T, DVR 800T

Applicant : Univent For Industrial Eng Co
Abou rawash - Industrial zone - Behind smart village - Giza- Egypt

Manufacturer : Shenzhen Chic Technology Co., Ltd.
No.507, Buidling 3rd, No.150 Huayue Road, Langkou Community,
Dalang Street, Longhua District Shenzhen.

Issued By : Shenzhen An-Teng Testing service Co., Ltd.
Floor 5, No. 11, Hebei Industrial Zone, Hualian Community,
Longhua Street, Longhua District, Shenzhen, China

Tel : +86 755 27724522

Fax : +86 755 27724533

Report Number : ATJC23080380002000E

Date of Test : Aug. 03 - 09, 2023

Issued Date : Aug. 09, 2023

Note:

This report shall not be reproduced except in full, without the written approval of Shenzhen An-Teng Testing Service Co., Ltd. This document may be altered or revised by Shenzhen An-Teng Testing Service Co., Ltd personnel only, and shall be noted in the revision section of the document. The test results in the report only apply to the tested sample.



TABLE OF CONTENTS

1. TEST CERTIFICATION	3
2. TEST RESULT SUMMARY	4
3. EUT DESCRIPTION	5
4. TEST METHODOLOGY	5
4.1. DECISION OF FINAL TEST MODE	5
4.2. EUT SYSTEM OPERATION	5
5. SETUP OF EQUIPMENT UNDER TEST	6
5.1. TEST INSTRUMENTS	6
5.2. CONFIGURATION OF SYSTEM UNDER TEST	7
6. FACILITIES AND ACCREDITATIONS	7
6.1. FACILITIES	7
6.2. MEASUREMENT UNCERTAINTY	7
7. EMISSION TEST	8
7.1. CONDUCTED EMISSION MEASUREMENT	8
7.2. RADIATED EMISSION MEASUREMENT	12
7.3. HARMONICS CURRENT MEASUREMENT	16
7.4. VOLTAGE FLUCTUATION AND FLICKS MEASUREMENT	19
8. IMMUNITY TEST	20
8.1. GENERAL DESCRIPTION	20
8.2. GENERAL PERFORMANCE CRITERIA DESCRIPTION	21
8.3. ELECTROSTATIC DISCHARGE (ESD)	21
8.4. RADIATED, RADIO-FREQUENCY, ELECTROMAGNETIC FIELD (RS)	25
8.5. ELECTRICAL FAST TRANSIENT (EFT)	27
8.6. SURGE IMMUNITY TEST	30
8.7. CONDUCTED RADIO FREQUENCY DISTURBANCES (CS)	32
8.8. POWER FREQUENCY MAGNETIC FIELD (PFMF)	34
8.9. VOLTAGE DIP & VOLTAGE INTERRUPTIONS	36
9. PHOTOGRAPHS OF EUT	38

1. TEST CERTIFICATION

Product:	ROOF FANS
Model:	DVR 280T, DVR 315T, DVR 355T, DVR 400T, DVR 450T, DVR 500T, DVR 560T, DVR 630T, DVR 710T, DVR 800T
Applicant:	Univent For Industrial Eng Co Abou rawash - Industrial zone - Behind smart village - Giza- Egypt
Factory:	Shenzhen Chic Technology Co., Ltd. No.507, Buidling 3rd, No.150 Huayue Road, Langkou Community, Dalang Street, Longhua District Shenzhen.
Test Voltage:	380V~, 50Hz
Applicable Standards:	EN IEC 55014-1:2021 EN IEC 55014-2:2021 EN IEC 61000-3-2:2019+A1:2021 EN 61000-3-3:2013+A2:2021

Deviation from Applicable Standard
None

The above equipment has been tested by Shenzhen An-Teng Testing Service Co., Ltd. and found compliance with the requirements set forth in the technical standards mentioned above. The results of testing in this report apply only to the product/system, which was tested. Other similar equipment will not necessarily produce the same results due to production tolerance and measurement uncertainties.

Tested By: Cris Song
(Cris Song)

Date: Aug. 09, 2023

Check By: Henry Tian
(Henry Tian)

Date: Aug. 09, 2023



2. TEST RESULT SUMMARY

EMISSION			
Standard	Item	Result	Remarks
EN IEC 55014-1:2021	Conducted (Main Port)	PASS	Meet limit
	Radiated emission	PASS	Meet limit
EN IEC 61000-3-2:2019+A1:2021	Harmonic current emissions	PASS	Meet limit
EN 61000-3-3:2013+A2:2021	Voltage fluctuations & flicker	PASS	Meet limit

IMMUNITY 【EN IEC 55014-2:2021】			
Standard	Item	Result	Remarks
EN 61000-4-2:2009	ESD	PASS	Meets the requirements of Performance Criterion B
EN IEC 61000-4-3:2020	RS	PASS	Meets the requirements of Performance Criterion A
EN 61000-4-4:2012	EFT	PASS	Meets the requirements of Performance Criterion B
EN 61000-4-5:2014+A1:2017	Surge	PASS	Meets the requirements of Performance Criterion B
EN 61000-4-6:2014+AC:2015	CS	PASS	Meets the requirements of Performance Criterion A
EN 61000-4-8:2010	PFMF	PASS	N/A
EN IEC 61000-4-11:2020	Voltage dips & voltage variations	PASS	Meets the requirements of Voltage dips: 1) 60% reduction performance Criterion C 2) 30% reduction performance Criterion C Voltage variations: 1)100% reduction performance Criterion C

Note:

1. The test result judgment is decided by the limit of test standard.
2. The information of measurement uncertainty is available upon the customer's request.

3. EUT DESCRIPTION

Product	ROOF FANS
Model Name	DVR 280T
Series No.	DVR 315T, DVR 355T, DVR 400T, DVR 450T, DVR 500T, DVR 560T, DVR 630T, DVR 710T, DVR 800T
Model Different	All models have the same mechanical and electrical construction, the difference is the size, power.
Housing Material	Metal
EUT Type	<input type="checkbox"/> Engineering Sample <input checked="" type="checkbox"/> Product Sample <input type="checkbox"/> Mass Product Sample
EUT Power Rating	380V~, 50Hz, 0.87-15.4A, 0.25-7.5kW
AC Mains	380V~

4. TEST METHODOLOGY

4.1. DECISION OF FINAL TEST MODE

The EUT was tested together with the thereafter additional components, and a configuration, which produced the worst emission levels, was selected and recorded in this report.

The following test mode(s) were scanned during the preliminary test:

Pre-Test Mode		
Emission	Conducted Emission	Mode: Normal Operating
	Radiated Emission	Mode: Normal Operating

After the preliminary scan, the following test mode was found to produce the highest emission level.

The Worst Test Mode		
Emission	Conducted Emission	Mode: Normal Operating
	Radiated Emission	Mode: Normal Operating

4.2. EUT SYSTEM OPERATION

1. Set up EUT with the support equipments.
2. Make sure the EUT work normally during the test.

5. SETUP OF EQUIPMENT UNDER TEST

5.1. TEST INSTRUMENTS

Immunity shielded room				
Name of Equipment	Manufacturer	Model	Serial Number	Calibration Due
EMC PARTNER TRANSIENT 2000	EMC PARTNER	TRA2000	881	10/30/2023
Power-frequency Magnetic field	SCHAFFNER	CCN 1000-1	72046	10/30/2023
Induction Coil Interface	SCHAFFNER	INA2141	6003	10/30/2023
Signal Generator	Maconi	2022D	119246/003	10/30/2023
Power Amplifier	M2S	A00181-1000	9801-112	10/30/2023
CDN	MEB	M3-8016	003683	10/30/2023
Power Amplifier	M2S	AC8113/ 800-250A	9801-179	10/30/2023
Power Antenna	SCHAFFNER	CBL6140A	1204	10/30/2023
ESD 2000	EMC PARTNER	ESD2000	182	10/30/2023
Harmonic & Flicker Tester	California instruments	PACS-3	SB2588/01	10/30/2023
AC Power Source	California instruments	5001iX-CTS-40	SB2588	10/30/2023
EMI Test Receiver	R&S	ESCI	100005	10/30/2023
Spectrum Analyzer	R&S	FSU	100114	10/30/2023
Pre Amplifier	H.P.	HP8447E	2945A02715	10/30/2023
Bilog Antenna	SUNOL Sciences	JB3	A021907	10/30/2023
Cable	TIME MICROWAVE	LMR-400	N-TYPE04	10/30/2023
System-Controller	CCS	N/A	N/A	N.C.R
Turn Table	CCS	N/A	N/A	N.C.R
Antenna Tower	CCS	N/A	N/A	N.C.R
Triple-Loop Antenna	EVERFINE	LLA-2	N/A	10/30/2023
LISN	AFJ	LS16	16010222119	10/30/2023
LISN(EUT)	Mestec	AN3016	04/10040	10/30/2023

NOTE:

1. The calibration interval of the above test instruments is 12 months and the calibrations are traceable to international system unit (SI).
2. N.C.R = No Calibration Request.

5.2. CONFIGURATION OF SYSTEM UNDER TEST

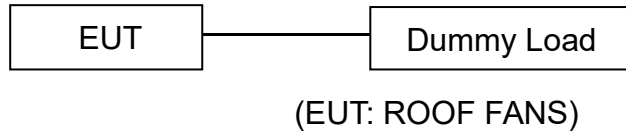

6. FACILITIES AND ACCREDITATIONS

6.1. FACILITIES

All measurement required was performed at laboratory of POCE Technology Co.,Ltd. 1F,Bldy.H,Hongfa Science and Technology park,Tangtou, Shiyan Street, Bao'an District, Shenzhen, China, F.R.C

6.2. MEASUREMENT UNCERTAINTY

Where relevant, the following measurement uncertainty levels have been estimated for tests performed on the EUT as specified in CISPR 16-4-2:

Measurement	Frequency	Uncertainty
Conducted emissions	150kHz~30MHz	+/- 3.59dB
Disturbance power	30MHz~1000MHz	+/- 4.77dB

This uncertainty represents an expanded uncertainty expressed at approximately the 95% confidence level using a coverage factor of k=2.

7. EMISSION TEST

7.1. CONDUCTED EMISSION MEASUREMENT

7.1.1. LIMITS

FREQUENCY (MHz)	At mains terminal		At load terminal and additional terminal	
	1	2	3	4
0.15 - 0.5	66 - 56	59 - 46	80	70
0.50 - 5.0	56	46	74	64
5.0 - 30.0	60	50	74	64

NOTE:

- (1) The lower limit shall apply at the transition frequencies.
- (2) The limit decreases in line with the logarithm of the frequency in the range of 0.15 to 0.50 MHz.
- (3) All emanations from device or system, including any network of conductors and apparatus connected thereto, shall not exceed the level of field strengths specified above.

7.1.2. TEST PROCEDURE

Procedure of Preliminary Test

The EUT and Support equipment, if needed, was set up as per the test configuration to simulate typical usage per the user's manual. When the EUT is a tabletop system, a wooden table with a height of 0.8 meters is used and is placed on the ground plane as per BS EN55014-1 (see Test Facility for the dimensions of the ground plane used). When the EUT is a floor standing equipment, it is placed on the ground plane, which has a 3-12 mm non-conductive covering to insulate the EUT from the ground plane.

All I/O cables were positioned to simulate typical actual usage as per BS EN55014-1.

All support equipment power received from a second LISN.

The EUT test program was started. Emissions were measured on each current carrying line of the EUT using an EMI Test Receiver connected to the LISN powering the EUT.

The Receiver scanned from 150 kHz to 30MHz for emissions in each of the test modes.

During the above scans, the emissions were maximized by cable manipulation.

The test mode(s) described in Item 3.1 were scanned during the preliminary test.

After the preliminary scan, we found the test mode described in Item 3.1 producing the highest emission level.

The EUT configuration and cable configuration of the above highest emission levels were recorded for reference of the final test.

Procedure of Final Test

EUT and support equipment were set up on the test bench as per the configuration with highest emission level in the preliminary test.

A scan was taken on both power lines, Line 1 and Line 2, recording at least the six highest emissions. Emission frequency and amplitude were recorded into a computer in which correction factors were used to calculate the emission level and compare reading to the applicable limit.

The test data of the worst-case condition(s) was recorded.

7.1.3. TEST SETUP

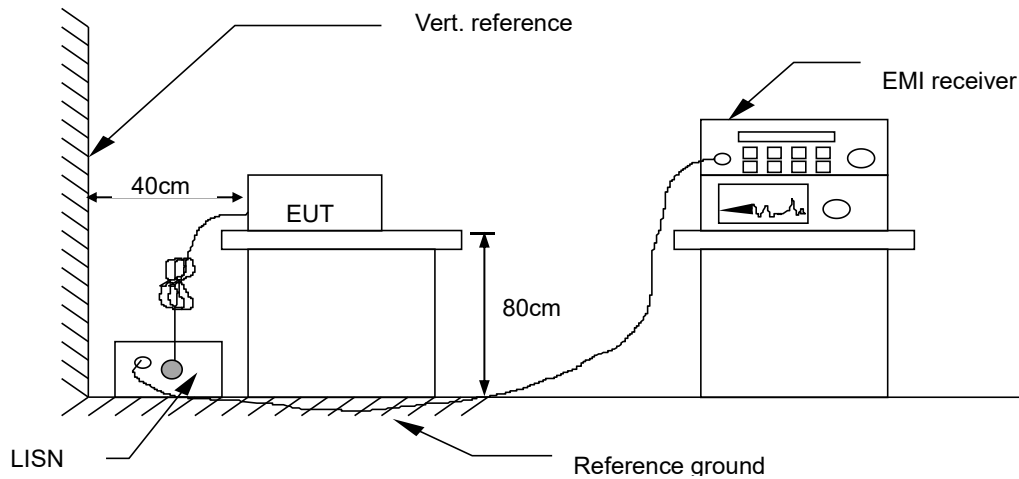

For the actual test configuration, please refer to the related item – Photographs of the Test Configuration.

7.1.4. TEST RESULTS

Temperature (°C)	22~28
Humidity (%RH)	50~54
Barometric Pressure (mbar)	950~1000
EUT	ROOF FANS
M/N	DVR 280T
Operating Mode	Normal Operating
Test Results	Pass

Please refer to following diagram for individual

EUT:	ROOF FANS	Model Name:	DVR 280T
Temperature:	24 °C	Relative Humidity:	54%
Pressure:	1010 hPa	Test Date:	Aug. 09, 2023
Test Mode:	ON	Polarization:	L
Test Power:	380V~, 50Hz, 0.25kW		

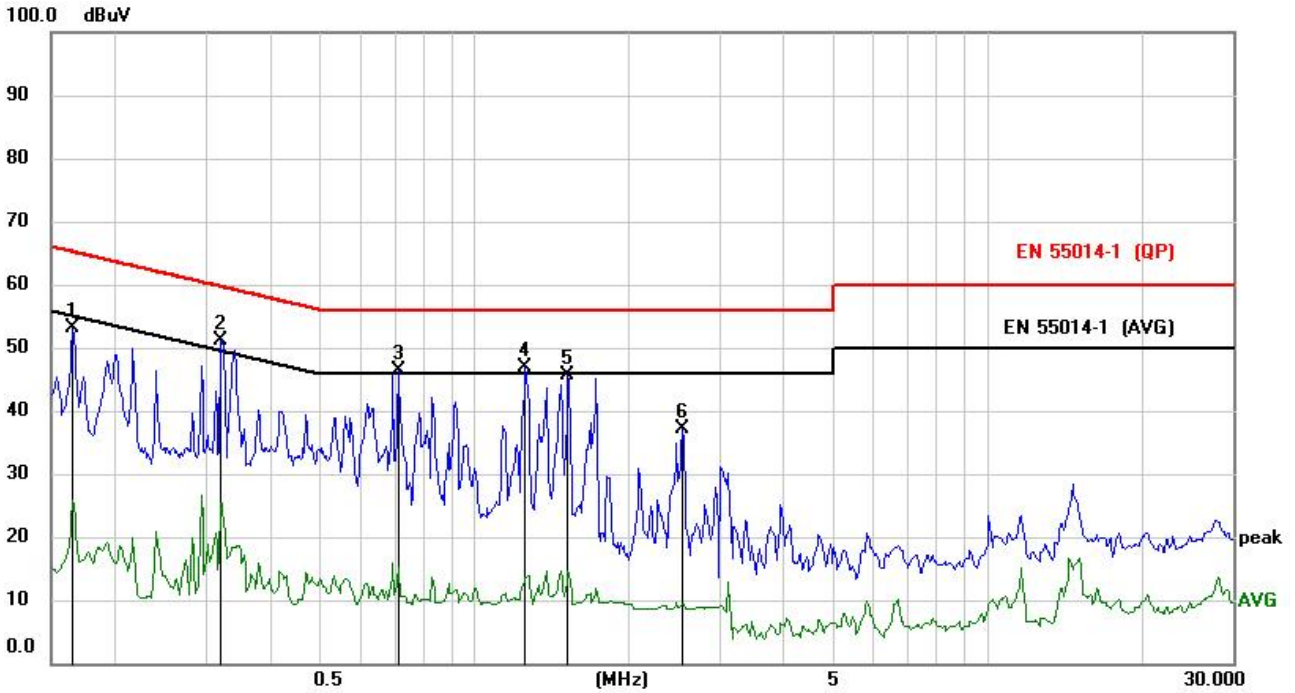

No.	Mk.	Freq. MHz	Reading Level dBuV	Correct Factor dB	Measure- ment dBuV	Limit dBuV	Over dB	Detector
1		0.1655	42.67	10.38	53.05	65.18	-12.13	peak
2	*	0.3215	40.77	10.42	51.19	59.67	-8.48	peak
3		0.7155	35.69	10.76	46.45	56.00	-9.55	peak
4		1.2576	36.02	10.88	46.90	56.00	-9.10	peak
5		1.5267	34.71	10.86	45.57	56.00	-10.43	peak
6		2.5485	26.25	10.83	37.08	56.00	-18.92	peak

EUT:	ROOF FANS	Model Name:	DVR 280T
Temperature:	24 °C	Relative Humidity:	54%
Pressure:	1010 hPa	Test Date:	Aug. 09, 2023
Test Mode:	ON	Polarization:	N
Test Power:	380V~, 50Hz, 0.25W		



No.	Mk.	Freq. MHz	Reading Level dBuV	Correct Factor dB	Measure- ment dBuV	Limit dBuV	Over dB	Detector
1		0.2046	37.86	10.20	48.06	63.42	-15.36	peak
2	*	0.3567	38.08	10.28	48.36	58.80	-10.44	peak
3		0.5673	33.60	10.45	44.05	56.00	-11.95	peak
4		1.1913	22.13	10.80	32.93	56.00	-23.07	peak
5		7.8321	27.47	11.09	38.56	60.00	-21.44	peak
6		14.6181	14.63	12.14	26.77	60.00	-33.23	peak

7.2. RADIATED EMISSION MEASUREMENT

7.2.1. LIMITS

FREQUENCY (MHz)	dBuV/m (At 3m)
30 ~ 230	40
230 ~ 1000	47

NOTE: (1) The lower limit shall apply at the transition frequencies.
 (2) Emission level (dBuV/m) = 20 log Emission level (uV/m).

7.2.2. TEST PROCEDURE

Procedure of Preliminary Test

The equipment was set up as per the test configuration to simulate typical usage per the user's manual. When the EUT is a tabletop system, a wooden turntable with a height of 0.8 meters is used which is placed on the ground plane. When the EUT is a floor standing equipment, it is placed on the ground plane which has a 3-12 mm non-conductive covering to insulate the EUT from the ground plane.

Support equipment, if needed, was placed as per BS EN 55015.

All I/O cables were positioned to simulate typical usage as per BS EN 55015.

Mains cables, telephone lines or other connections to auxiliary equipment located outside the test are shall drape to the floor, be fitted with ferrite clamps or ferrite tubes placed on the floor at the point where the cable reaches the floor and then routed to the place where they leave the turntable. No extension cords shall be used to mains receptacle.

The antenna was placed at 3 meter away from the EUT as stated in EN 55015. The antenna connected to the Spectrum Analyzer via a cable and at times a pre-amplifier would be used.

The Analyzer / Receiver quickly scanned from 30MHz to 1000MHz. The EUT test program was started. Emissions were scanned and measured rotating the EUT to 360 degrees and positioning the antenna 1 to 4 meters above the ground plane, in both the vertical and the horizontal polarization, to maximize the emission reading level.

The test mode(s) described in Item 3.1 were scanned during the preliminary test:

After the preliminary scan, we found the test mode described in Item 3.1 producing the highest emission level. The EUT and cable configuration, antenna position, polarization and turntable position of the above highest emission level were recorded for the final test.

Procedure of Final Test

EUT and support equipment were set up on the turntable as per the configuration with highest emission level in the preliminary test.

The Analyzer / Receiver scanned from 30MHz to 1000MHz. Emissions were scanned and measured rotating the EUT to 360 degrees, varying cable placement and positioning the antenna 1 to 4 meters above the ground plane, in both the vertical and the horizontal polarization, to maximize the emission reading level.

Recorded at least the six highest emissions. Emission frequency, amplitude, antenna position, polarization and turntable position were recorded into a computer in which correction factors were used to calculate the emission level and compare reading to the applicable limit and only Q.P. reading is presented.

The test data of the worst-case condition(s) was recorded.

7.2.3. TEST SETUP

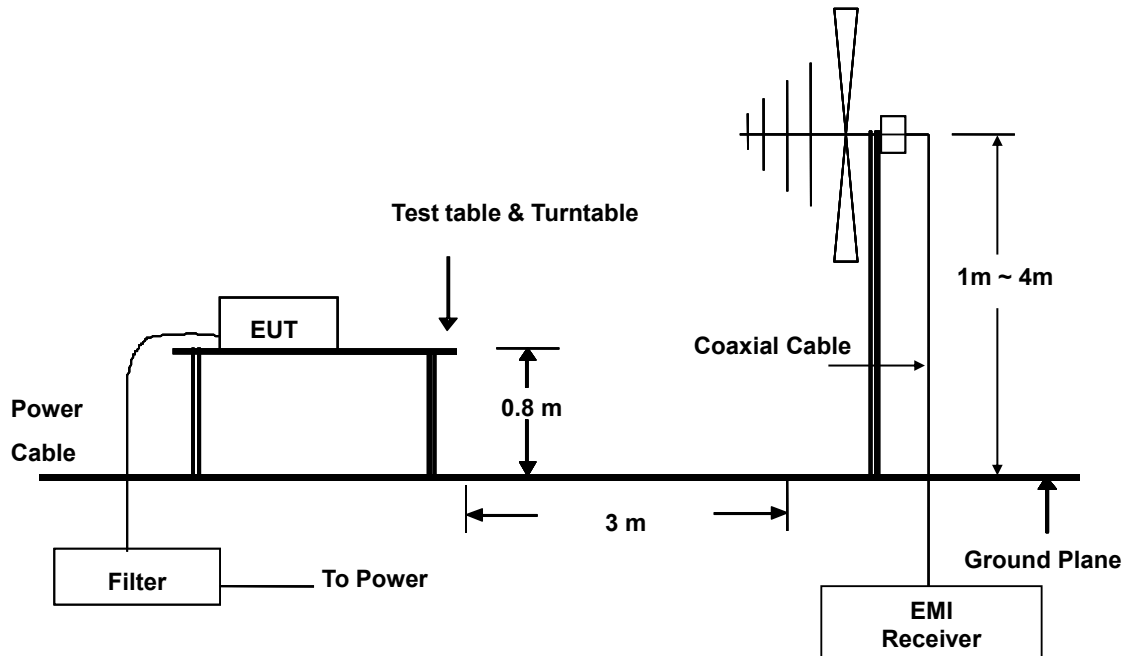

For the actual test configuration, please refer to the related item – Photographs of the Test Configuration.

7.2.4 TEST RESULTS

Temperature (°C)	22~28
Humidity (%RH)	50~54
Barometric Pressure (mbar)	950~1000
EUT	ROOF FANS
M/N	DVR 280T
Operating Mode	Normal Operating
Test Results	PASS

Please refer to following diagram for individual

EUT:	ROOF FANS	Model Name:	DVR 280T
Temperature:	26 °C	Relative Humidity:	54%
Pressure:	1010hPa	Test Date:	Aug. 09, 2023
Test Mode:	ON	Phase:	Horizontal
Test Voltage:	380V~, 50Hz, 0.25W		

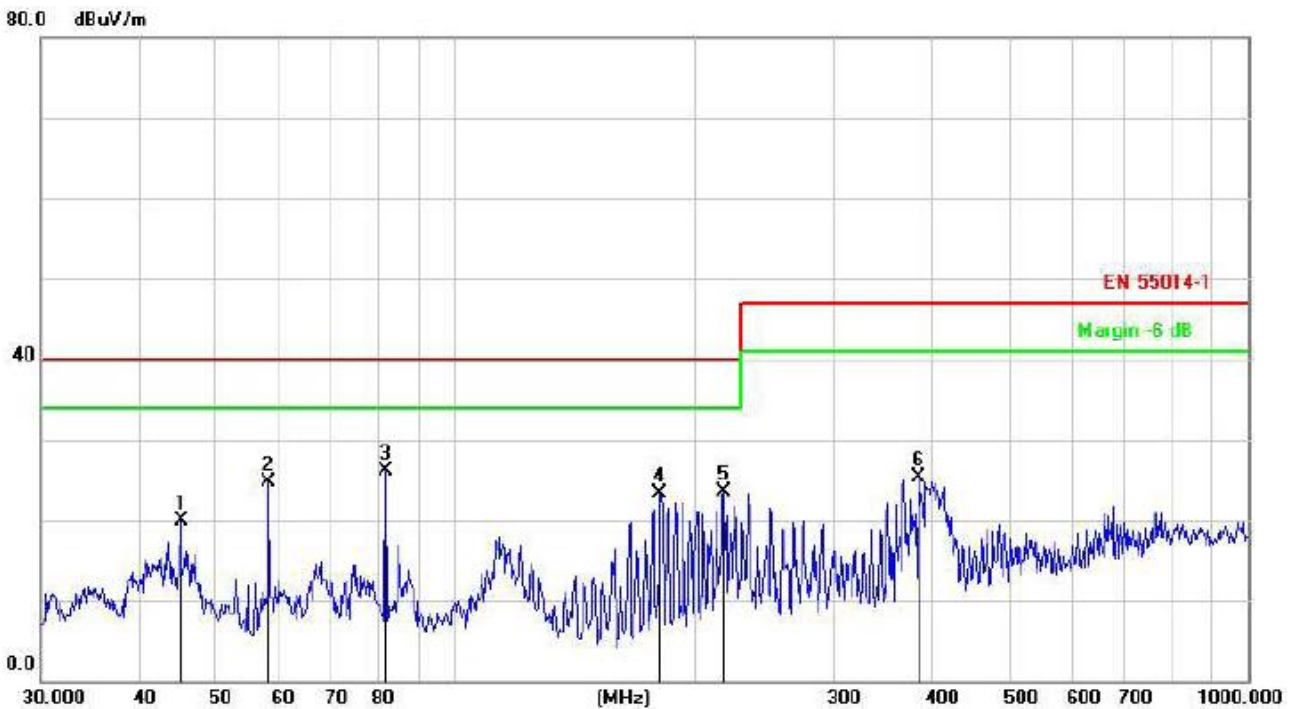

No.	Mk.	Freq. MHz	Reading Level dBuV	Correct Factor dB	Measure- ment dBuV/m	Limit dB/m	Over dB	Detector
1		45.0583	37.82	-17.89	19.93	40.00	-20.07	peak
2		58.2030	43.43	-18.70	24.73	40.00	-15.27	peak
3	*	81.7833	46.92	-20.90	26.02	40.00	-13.98	peak
4		181.2834	41.43	-18.15	23.28	40.00	-16.72	peak
5		218.3085	42.88	-19.46	23.42	40.00	-16.58	peak
6		383.9318	42.30	-17.06	25.24	47.00	-21.76	peak

EUT:	ROOF FANS	Model Name:	DVR 280T
Temperature:	26 °C	Relative Humidity:	54%
Pressure:	1010hPa	Test Date:	Aug. 09, 2023
Test Mode:	ON	Phase:	Vertical
Test Voltage:	380V~, 50Hz, 0.25kW		

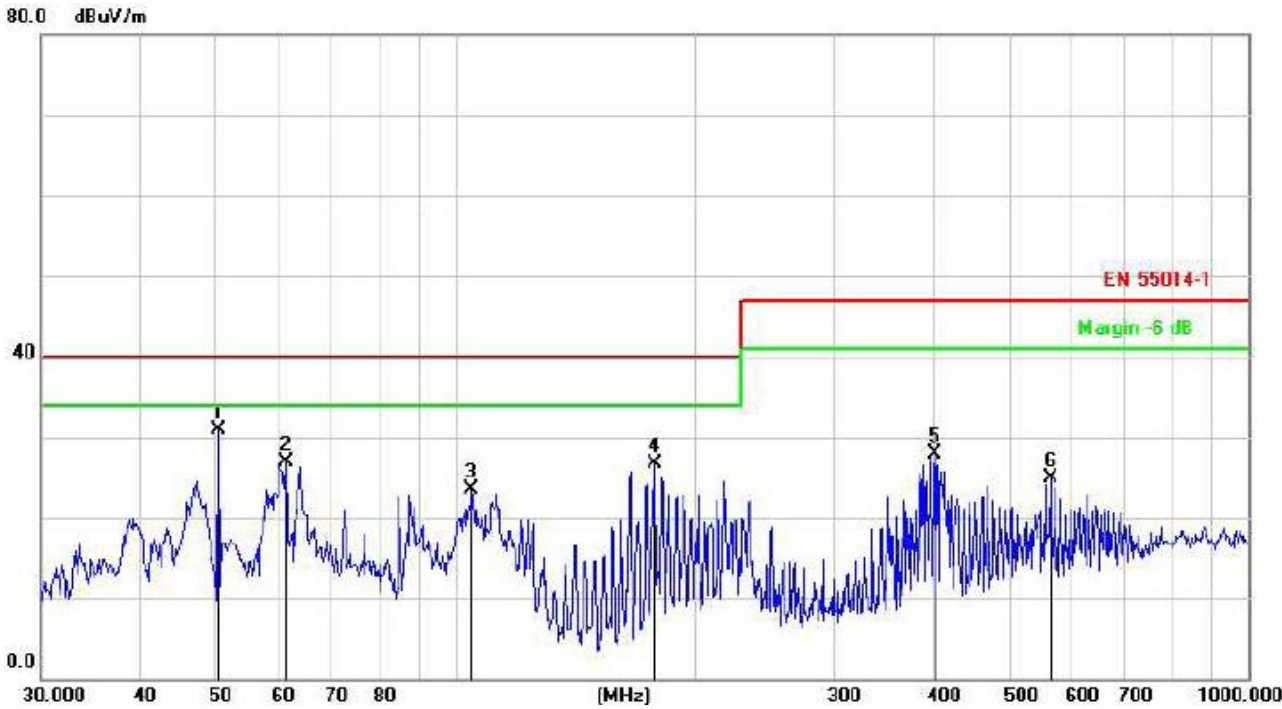

No.	Mk.	Freq. MHz	Reading Level dBuV	Correct Factor dB	Measure- ment dBuV/m	Limit dB/m	Over dB	Detector
1	*	50.2324	49.48	-18.48	31.00	40.00	-9.00	peak
2		61.1316	45.74	-18.89	26.85	40.00	-13.15	peak
3		104.9033	43.81	-20.36	23.45	40.00	-16.55	peak
4		178.7584	44.39	-17.69	26.70	40.00	-13.30	peak
5		401.8385	45.10	-17.12	27.98	47.00	-19.02	peak
6		562.6624	38.78	-13.97	24.81	47.00	-22.19	peak

7.3. HARMONICS CURRENT MEASUREMENT

7.3.1. LIMITS OF HARMONICS CURRENT MEASUREMENT

Limits for Class A equipment		Limits for Class D equipment		
Harmonics Order n	Max. permissible harmonics current A	Harmonics Order n	Max. permissible harmonics current per watt mA/W	Max. permissible harmonics current A
Odd harmonics		Odd Harmonics only		
3	2.30	3	3.4	2.30
5	1.14	5	1.9	1.14
7	0.77	7	1.0	0.77
9	0.40	9	0.5	0.40
11	0.33	11	0.35	0.33
13	0.21	13	0.30	0.21
15<=n<=39	0.15x15/n	15<=n<=39	3.85/n	0.15x15/n
Even harmonics				
2	1.08			
4	0.43			
6	0.30			
8<=n<=40	0.23x8/n			

NOTE: 1. Class A and Class D are classified according to item 4.4.3.
 2. According to section 7 of EN IEC 61000-3-2, the above limits apply for all equipments with a rated power more than 75W, except for lighting equipment.

7.3.2. TEST PROCEDURE

The EUT was placed on the top of a wooden table 0.8 meters above the ground and operated to produce the maximum harmonic components under Running operating conditions for each successive harmonic component in turn. The classification of EUT is according to section 5 of EN IEC 61000-3-2.

The EUT is classified as follows:

- Class A: Balanced three-phase equipment, Household appliances excluding equipment as Class D, Tools excluding portable tools, Dimmers for incandescent lamps, audio equipment, equipment not specified in one of the three other classes.
- Class B: Portable tools; Arc welding equipment which is not professional equipment.
- Class C: Lighting equipment.
- Class D: Equipment having a specified power less than or equal to 600 W of the following types: Personal computers and personal computer monitors and television receivers.

The correspondent test program of test instrument to measure the current harmonics emanated from EUT is chosen. The measure time shall be not less than the time necessary for the EUT to be exercised.

7.3.3. TEST SETUP

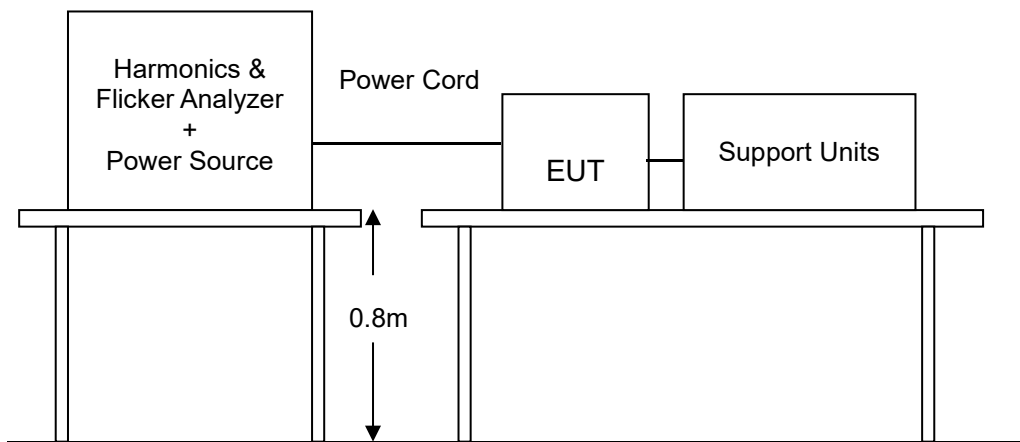

For the actual test configuration, please refer to the related item.

7.3.4. TEST RESULTS

PASS

Please refer to following diagram for individual

Fundamental :		373.1				
2 :	1080.0	1.6	0.1	3.6	0.3	Pass
3 :	2300.0	352.6	15.3	354.6	15.4	Pass
4 :	430.0	1.8	0.4	3.4	0.8	Pass
5 :	1140.0	323.6	28.4	324.7	28.5	Pass
6 :	300.0	2.0	0.7	3.0	1.0	Pass
7 :	770.0	283.7	36.8	284.1	36.9	Pass
8 :	230.0	2.0	0.9	2.6	1.1	Pass
9 :	400.0	236.4	59.1	237.1	59.3	Pass
10 :	184.0	1.9	1.0	2.4	1.3	Pass
11 :	330.0	186.2	56.4	187.5	56.8	Pass
12 :	153.3	1.8	1.2	2.1	1.4	Pass
13 :	210.0	137.3	65.4	139.2	66.3	Pass
14 :	131.4	1.5	1.1	1.8	1.4	Pass
15 :	150.0	94.1	62.7	96.1	64.1	Pass
16 :	115.0	1.2	1.0	1.6	1.4	Pass
17 :	132.3	60.7	45.9	62.3	47.1	Pass
18 :	102.2	1.0	1.0	1.4	1.4	Pass
19 :	118.4	41.1	34.7	41.8	35.3	Pass
20 :	92.0	0.8	0.9	1.3	1.4	Pass
21 :	107.1	35.4	33.1	35.7	33.3	Pass
22 :	83.6	0.7	0.8	1.1	1.3	Pass
23 :	97.8	35.3	36.1	35.7	36.5	Pass
24 :	76.7	0.6	0.8	1.0	1.3	Pass
25 :	90.0	33.4	37.1	33.5	37.2	Pass
26 :	70.8	0.6	0.8	0.9	1.3	Pass
27 :	83.3	28.2	33.9	28.5	34.2	Pass
28 :	65.7	0.6	0.9	0.8	1.2	Pass
29 :	77.6	20.9	26.9	21.4	27.6	Pass
30 :	61.3	0.5	0.8	0.6	1.0	Pass
31 :	72.6	13.3	18.3	13.9	19.1	Pass
32 :	57.5	0.4	0.7	0.5	0.9	Pass
33 :	68.2	8.4	12.3	8.6	12.6	Pass
34 :	54.1	0.3	0.6	0.5	0.9	Pass
35 :	64.3	8.4	13.1	8.9	13.8	Pass
36 :	51.1	0.3	0.6	0.5	1.0	Pass
37 :	60.8	9.9	16.3	10.3	16.9	Pass
38 :	48.4	0.3	0.6	0.5	1.0	Pass
39 :	57.7	10.1	17.5	10.2	17.7	Pass
40 :	46.0	0.3	0.7	0.4	0.9	Pass
21 - 39 :	251.4	73.2	29.1	73.6	29.3	-

7.4. VOLTAGE FLUCTUATION AND FLICKS MEASUREMENT

7.4.1. LIMITS OF VOLTAGE FLUCTUATION AND FLICKS MEASUREMENT

TEST ITEM	LIMIT	REMARK
P_{st}	1.0	P_{st} means short-term flicker indicator.
P_{lt}	0.65	P_{lt} means long-term flicker indicator.
T_{dt} (ms)	500	T_{dt} means maximum time that dt exceeds 3 %.
d_{max} (%)	4%	d_{max} means maximum relative voltage change.
dc (%)	3.3%	dc means relative steady-state voltage change

7.4.2. TEST PROCEDURE

The EUT was placed on the top of a wooden table 0.8 meters above the ground and operated to produce the most unfavorable sequence of voltage changes under Running operating conditions.

During the flick measurement, the measure time shall include that part of whole operation cycle in which the EUT produce the most unfavorable sequence of voltage changes. The observation period for short-term flicker indicator is 10 minutes and the observation period for long-term flicker indicator is 2 hours.

7.4.3. TEST SETUP

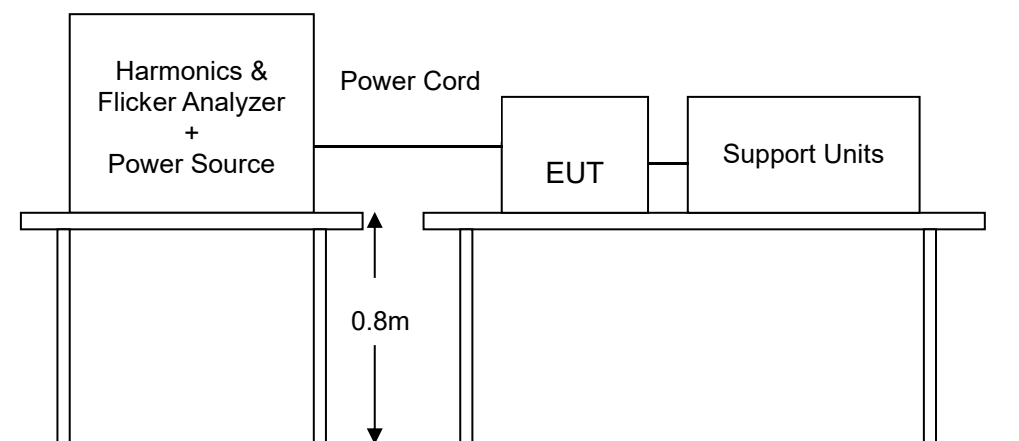

For the actual test configuration, please refer to the related item.

7.4.4. TEST RESULTS

N/A

8. IMMUNITY TEST

8.1. GENERAL DESCRIPTION

Product Standard	EN 55014-2	
	Test Type	Minimum Requirement
Basic Standard, Specification, and Performance Criterion required	EN 61000-4-2	Electrostatic Discharge – ESD: 8kV air discharge, 4kV Contact discharge, Performance Criterion B
	EN IEC 61000-4-3	Radio-Frequency Electromagnetic Field Susceptibility Test – RS: 80 ~1000 MHz, 3V/m, 80% AM(1kHz), Performance Criterion A
	EN 61000-4-4	Electrical Fast Transient/Burst - EFT, Power line: 1kV, Signal line: 0.5kV, Performance Criterion B
	EN 61000-4-5	Surge Immunity Test: 1.2/50 us Open Circuit Voltage, 8 /20 us Short Circuit Current, Power Port ~ Line to line: 1kV, Line to ground: 2kV Signal Port ~ Lines to ground : 1kV Performance Criterion B
	EN 61000-4-6	Conducted Radio Frequency Disturbances Test –CS: 0.15 ~ 230 MHz, 3Vrms, 80% AM, 1kHz, Performance Criterion A
	EN 61000-4-8	N/A
	EN 61000-4-11	Voltage Dips: i) 30% reduction for 50 period, Performance Criterion C ii) 60% reduction for 10 period, Performance Criterion C Voltage Interruptions: 100% reduction for 0.5 period Performance Criterion C

8.2. GENERAL PERFORMANCE CRITERIA DESCRIPTION

<p>Criteria A:</p>	<p>The apparatus shell continues to operate as intended without operator intervention. No degradation of performance or loss of function is allowed below a performance level specified by the manufacturer, when the apparatus is used as intended. The performance level may be replaced by a permissible loss of performance. If the manufacturer does not specify the minimum performance level or the permissible performance loss, then either of these may be derived from the product description and documentation, and by what the user may reasonably expect from the equipment if used as intended.</p>
<p>Criteria B:</p>	<p>After test, the apparatus shell continues to operate as intended without operator intervention. No degradation of performance or loss of function is allowed, after the application of the phenomenon below a performance level specified by the manufacturer, when the apparatus is used as intended. The performance level may be replaced by a permissible loss of performance.</p> <p>During the test, degradation of performance is however allowed. However, no change of operating state if stored data is allowed to persist after the test. If the manufacturer does not specify the minimum performance level or the permissible performance loss, then either of these may be derived from the product description and documentation, and by what the user may reasonably expect from the equipment if used as intended.</p>
<p>Criteria C:</p>	<p>Temporary loss of function is allowed, provided the functions is self-recoverable or can be restored by the operation of controls by the user in accordance with the manufacturer instructions.</p> <p>Functions, and/or information stored in non-volatile memory, or protected by a battery backup, shall not be lost.</p>

8.3. ELECTROSTATIC DISCHARGE (ESD)

8.3.1. TEST SPECIFICATION

Basic Standard:	EN 61000-4-2
Discharge Impedance:	330 ohm
Charging Capacity:	150pF
Discharge Voltage:	Air Discharge: 8 kV (Direct) Contact Discharge: 4 kV (Direct/Indirect)
Polarity:	Positive & Negative
Number of Discharge:	Minimum 10 times at each test point
Discharge Mode:	1 time/s
Performance Criterion:	B

8.3.2. TEST PROCEDURE

The discharges shall be applied in two ways:

- a) Contact discharges to the conductive surfaces and coupling planes:
Twenty dischargers (10 with positive and 10 with negative polarity) shall be applied on each accessible metallic part of the enclosure, terminals are excluded. In case of a non-conductive enclosure, dischargers shall be applied on the horizontal or vertical coupling planes. Test shall be performed at a maximum repetition rate of one discharge per second.
- b) Air discharges at slots and apertures and insulating surfaces:
On those parts of the EUT where it is not possible to perform contact discharge testing, the equipment should be investigated to identify user accessible points where breakdown may occur. Such points are tested using the air discharge method. This investigation should be restricted to those area normally handled by the user. A minimum of 10 single air discharges shall be applied to the selected test point for each such area.

The basic test procedure was in accordance with IEC 61000-4-2:

- a) The EUT was located 0.1 m minimum from all side of the **HCP** (dimensions 1.6m x 0.8m).
- b) The support units were located another table 30 cm away from the EUT, but direct support unit was/were located at same location as EUT on the HCP and keep at a distance of 10 cm with EUT.
- c) The time interval between two successive single discharges was at least 1 second.
- d) Contact discharges were applied to the non-insulating coating, with the pointed tip of the generator penetrating the coating and contacting the conducting substrate.
- e) Air discharges were applied with the round discharge tip of the discharge electrode approaching the EUT as fast as possible (without causing mechanical damage) to touch the EUT. After each discharge, the ESD generator was removed from the EUT and re-triggered for a new single discharge. The test was repeated until all discharges were complete.
- f) At least ten single discharges (in the most sensitive polarity) were applied at the front edge of each **HCP** opposite the center point of each unit of the EUT and 0.1 meters from the front of the EUT. The long axis of the discharge electrode was in the plane of the **HCP** and perpendicular to its front edge during the discharge.
- g) At least ten single discharges (in the most sensitive polarity) were applied to the center of one vertical edge of the **Vertical Coupling Plane (VCP)** in sufficiently different positions that the four faces of the EUT were completely illuminated. The **VCP** (dimensions 0.5m x 0.5m) was placed vertically to and 0.1 meters from the EUT.

8.3.3. TEST SETUP

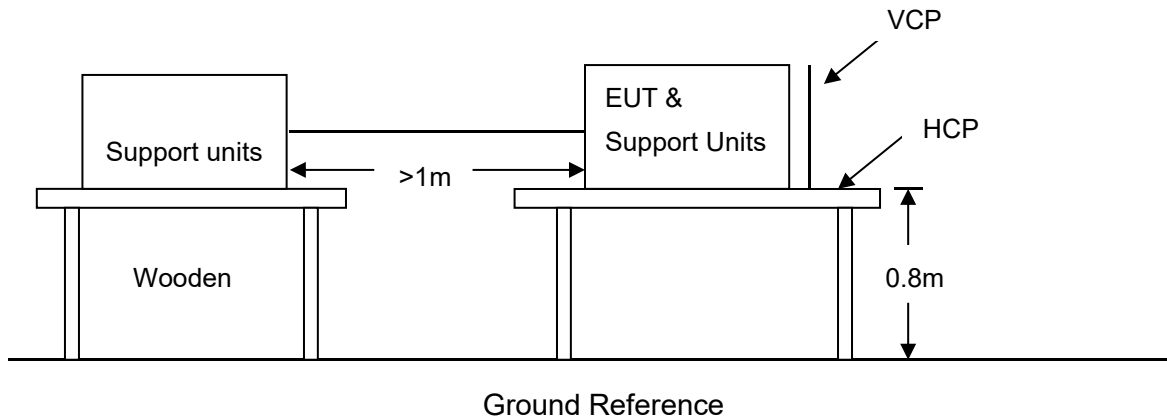

For the actual test configuration, please refer to the related item – Photographs of the Test Configuration.

NOTE:

TABLE-TOP EQUIPMENT

The configuration consisted of a wooden table 0.8 meters high standing on the **Ground Reference Plane**. The **GRP** consisted of a sheet of aluminum at least 0.25mm thick, and 2.5 meters square connected to the protective grounding system. A **Horizontal Coupling Plane** (1.6m x 0.8m) was placed on the table and attached to the **GRP** by means of a cable with 940k total impedance. The equipment under test, was installed in a representative system as described in section 7 of EN 61000-4-2, and its cables were placed on the **HCP** and isolated by an insulating support of 0.5mm thickness. A distance of 1-meter minimum was provided between the EUT and the walls of the laboratory and any other metallic structure.

FLOOR-STANDING EQUIPMENT

The equipment under test was installed in a representative system as described in section 7 of IEC 61000-4-2, and its cables were isolated from the Ground Reference Plane by an insulating support of 0.1-meter thickness. The GRP consisted of a sheet of aluminum that is at least 0.25mm thick, and 2.5 meters square connected to the protective grounding system and extended at least 0.5 meters from the EUT on all sides.

8.3.4. TEST RESULTS

Temperature (°C)	22~28
Humidity (%RH)	50~54
Barometric Pressure (mbar)	950~1000
EUT	ROOF FANS
M/N	DVR 280T
Operating Mode	Normal Operating
Test Results	Pass

Air Discharge						
Test locations		Test Levels	Results			
		± 8 kV	Pass	Fail	Performance Criterion	Observation
Slot	4 Points	<input checked="" type="checkbox"/>	<input checked="" type="checkbox"/>	<input type="checkbox"/>	B	Note <input type="checkbox"/> 1 <input checked="" type="checkbox"/> 2

Contact Discharge						
Test locations		Test Levels	Results			
		± 4 kV	Pass	Fail	Performance Criterion	Observation
HCP	4 Points	<input checked="" type="checkbox"/>	<input checked="" type="checkbox"/>	<input type="checkbox"/>	B	Note <input type="checkbox"/> 1 <input checked="" type="checkbox"/> 2
VCP	4 Points	<input checked="" type="checkbox"/>	<input checked="" type="checkbox"/>	<input type="checkbox"/>	B	Note <input type="checkbox"/> 1 <input checked="" type="checkbox"/> 2
Port	1 Points	<input checked="" type="checkbox"/>	<input checked="" type="checkbox"/>	<input type="checkbox"/>	B	Note <input type="checkbox"/> 1 <input checked="" type="checkbox"/> 2

NOTE:

1. There was no change compared with initial operation during the test.
2. The loss of function of the EUT during the test and it was recovered by itself operation after the test.

8.4. RADIATED, RADIO-FREQUENCY, ELECTROMAGNETIC FIELD (RS)

8.4.1. TEST SPECIFICATION

Basic Standard: EN IEC 61000-4-3

Frequency Range: 80 MHz ~1000 MHz

Field Strength: 3 V/m

Modulation: 1kHz Sine Wave, 80%, AM Modulation

Frequency Step: 1 % of preceding frequency value

Polarity of Antenna: Horizontal and Vertical

Test Distance: 3 m

Antenna Height: 1.5m

Performance Criterion: A

8.4.2. TEST PROCEDURE

The test procedure was in accordance with EN IEC 61000-4-3

- a) The testing was performed in a fully anechoic chamber. The transmit antenna was located at a distance of 3 meters from the EUT.
- b) The frequency range is swept from 80 MHz to 1000 MHz, with the signal 80% amplitude modulated with a 1kHz sine-wave. The rate of sweep did not exceed 1.5×10^{-3} decade/s, where the frequency range is swept incrementally the step size was 1% of preceding frequency value.
- c) The dwell time at each frequency shall be not less than the time necessary for the EUT to be able to respond.
- d) The test was performed with the EUT exposed to both vertically and horizontally polarized fields on each of the four sides.

8.4.3. TEST SETUP

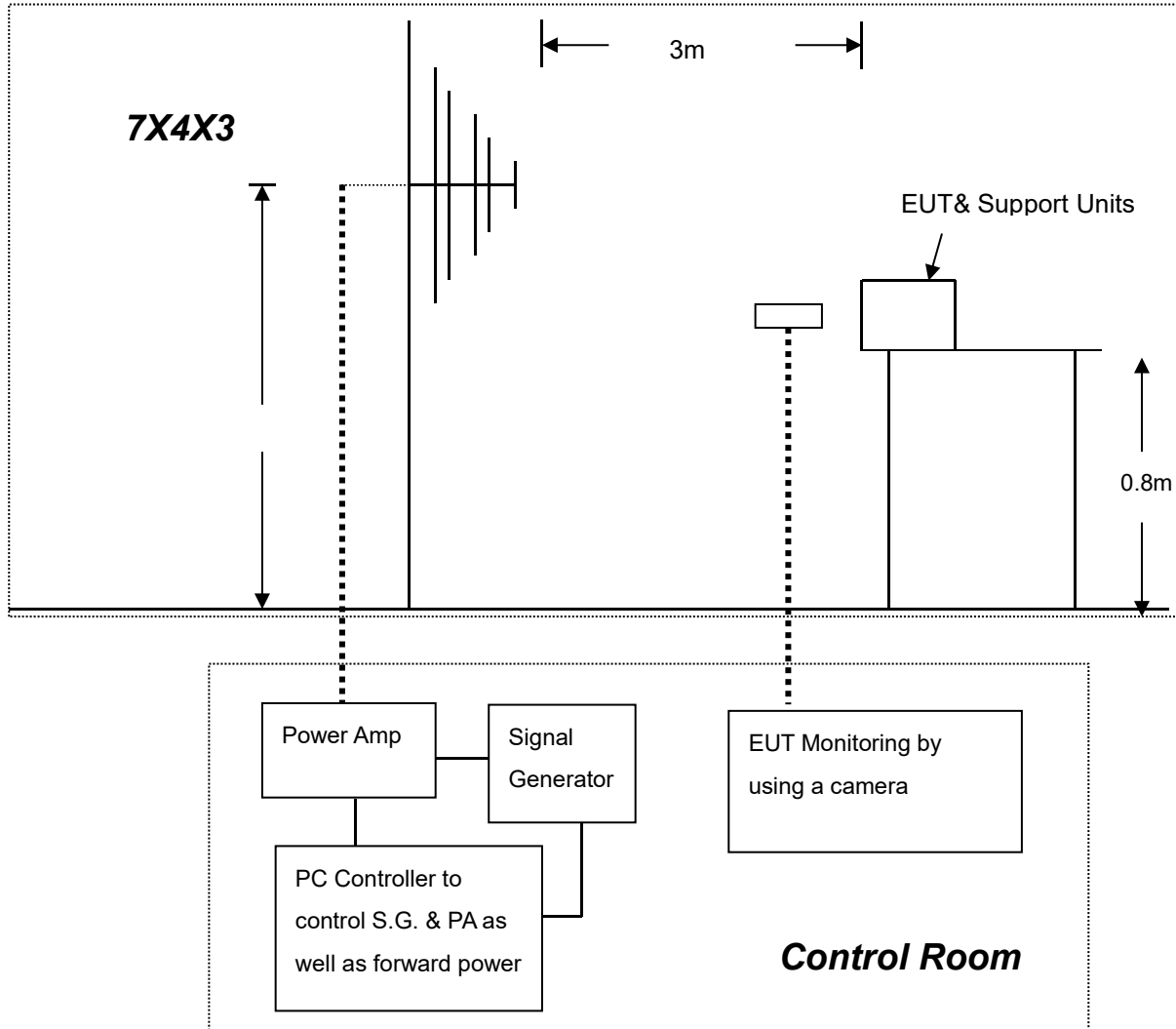

For the actual test configuration, please refer to the related item.

NOTE:

TABLETOP EQUIPMENT

The EUT installed in a representative system as described in section 7 of EN IEC 61000-4-3 was placed on a non-conductive table 0.8 meters in height. The system under test was connected to the power and signal wire according to relevant installation instructions.

FLOOR STANDING EQUIPMENT

The EUT installed in a representative system as described in section 7 of IEC 61000-4-3 was placed on a non-conductive wood support 0.1 meters in height. The system under test was connected to the power and signal wire according to relevant installation instructions.

8.4.4. TEST RESULTS

Temperature (°C)	22~28
Humidity (%RH)	50~54
Barometric Pressure (mbar)	950~1000
EUT	ROOF FANS
M/N	DVR 280T
Operating Mode	Normal Operating
Test Results	Pass

Frequency (MHz)	Polarity	Position	Field Strength (V/m)	Observation	Result
80 ~ 1000	V&H	Front	3	Note	PASS
80 ~ 1000	V&H	Rear	3	Note	PASS
80 ~ 1000	V&H	Left	3	Note	PASS
80 ~ 1000	V&H	Right	3	Note	PASS

8.5. ELECTRICAL FAST TRANSIENT (EFT)

8.5.1. TEST SPECIFICATION

Basic Standard:	EN 61000-4-4
Test Voltage:	Power Line: 1 kV Signal/Control Line: 0.5 kV
Polarity:	Positive & Negative
Impulse Frequency:	5 kHz
Impulse Wave-shape:	5/50 ns
Burst Duration:	15 ms
Burst Period:	300 ms
Test Duration:	Not less than 1 min.
Performance criterion:	B

8.5.2. TEST PROCEDURE

- a) Both positive and negative polarity discharges were applied.
- b) The length of the “hot wire” from the coaxial output of the EFT generator to the terminals on the EUT should not exceed 1 meter.
- c) The duration time of each test sequential was 1 minute.
- d) The transient/burst waveform was in accordance with EN 61000-4-4, 5/50ns.

8.5.3. TEST SETUP

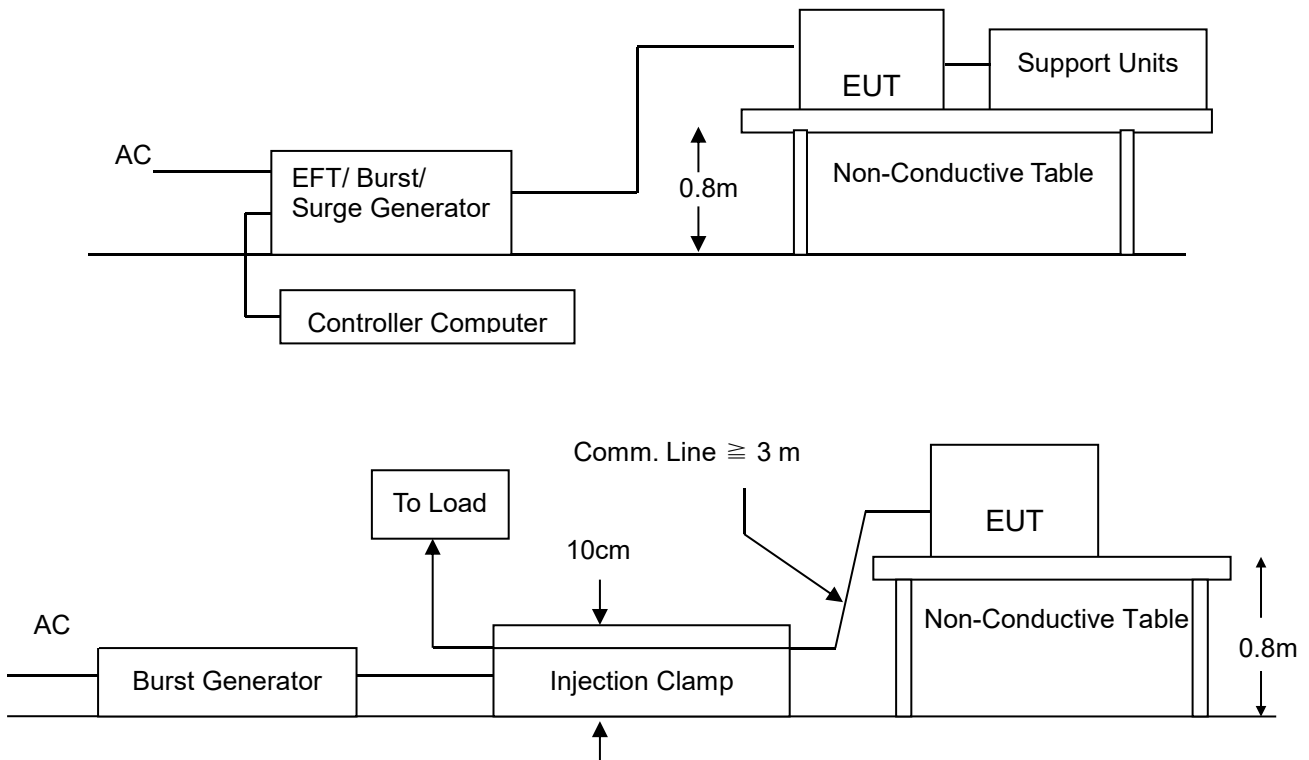

For the actual test configuration, please refer to the related item – Photographs of the Test Configuration.

NOTE:

TABLETOP EQUIPMENT

The configuration consisted of a wooden table (0.8m high) standing on the Ground Reference Plane. The GRP consisted of a sheet of aluminum (at least 0.25mm thick and 2.5m square) connected to the protective grounding system. A minimum distance of 0.5m was provided between the EUT and the walls of the laboratory or any other metallic structure.

FLOOR STANDING EQUIPMENT

The EUT installed in a representative system as described in section 7 of IEC 61000-4-4 and its cables, were isolated from the Ground Reference Plane by an insulating support that is 0.1-meter thick. The GRP consisted of a sheet of aluminum (at least 0.25mm thick and 2.5m square) connected to the protective grounding system.

8.5.4. TEST RESULTS

Temperature (°C)	22~28
Humidity (%RH)	50~54
Barometric Pressure (mbar)	950~1000
EUT	ROOF FANS
M/N	DVR 280T
Operating Mode	Normal Operating
Test Results	Pass

Test Point	Polarity	Test Level (kV)	Performance Criterion	Observation	Result
L	+/-	1	B	Note <input type="checkbox"/> 1 <input checked="" type="checkbox"/> 2	PASS
N	+/-	1	B	Note <input type="checkbox"/> 1 <input checked="" type="checkbox"/> 2	PASS
L – N	+/-	1	B	Note <input type="checkbox"/> 1 <input checked="" type="checkbox"/> 2	PASS
PE	--	--	--	Note <input type="checkbox"/> 1 <input type="checkbox"/> 2	N/A
L – PE	--	--	--	Note <input type="checkbox"/> 1 <input type="checkbox"/> 2	N/A
N – PE	--	--	--	Note <input type="checkbox"/> 1 <input type="checkbox"/> 2	N/A
L – N – PE	--	--	--	Note <input type="checkbox"/> 1 <input type="checkbox"/> 2	N/A
RJ45 UTP cable	--	--	--	Note <input type="checkbox"/> 1 <input type="checkbox"/> 2	N/A

NOTE:

1. There was no change compared with initial operation during the test.
2. The loss of function of the EUT during the test and it was recovered by itself operation after the test.

8.6. SURGE IMMUNITY TEST

8.6.1. TEST SPECIFICATION

Basic Standard:	EN 61000-4-5
Wave-Shape:	Combination Wave 1.2/50 us Open Circuit Voltage 8/20 us Short Circuit Current
Test Voltage:	Power line ~ line to line: 1 kV line to ground: 2kV Telecommunication line: 1 kV
Surge Input/Output:	Power Line: L-N / L-PE / N-PE Telecommunication line: T-Ground / R-Ground
Generator Source Impedance:	2 ohm between networks 12 ohm between network and ground
Polarity:	Positive/Negative
Phase Angle:	0 /90 /180 /270
Pulse Repetition Rate:	1 time / min. (maximum)
Number of Tests:	5 positive and 5 negative at selected points
Performance Criterion:	B

8.6.2. TEST PROCEDURE

- a) For EUT power supply:
The surge is applied to the EUT power supply terminals via the capacitive coupling network. Decoupling networks are required in order to avoid possible adverse effects on equipment not under test that may be powered by the same lines, and to provide sufficient decoupling impedance to the surge wave. The power cord between the EUT and the coupling/decoupling networks was shorter than 2 meters in length.
- b) For test applied to unshielded un-symmetrically operated interconnection lines of EUT:
The surge was applied to the lines via the capacitive coupling. The coupling / decoupling networks didn't influence the specified functional conditions of the EUT. The interconnection line between the EUT and the coupling/decoupling networks was shorter than 2 meters in length.
- c) For test applied to unshielded symmetrically operated interconnection / telecommunication lines of EUT:
The surge was applied to the lines via gas arrestors coupling. Test levels below the ignition point of the coupling arrestor were not specified. The interconnection line between the EUT and the coupling/decoupling networks was shorter than 2 meters in length.

8.6.3. TEST SETUP

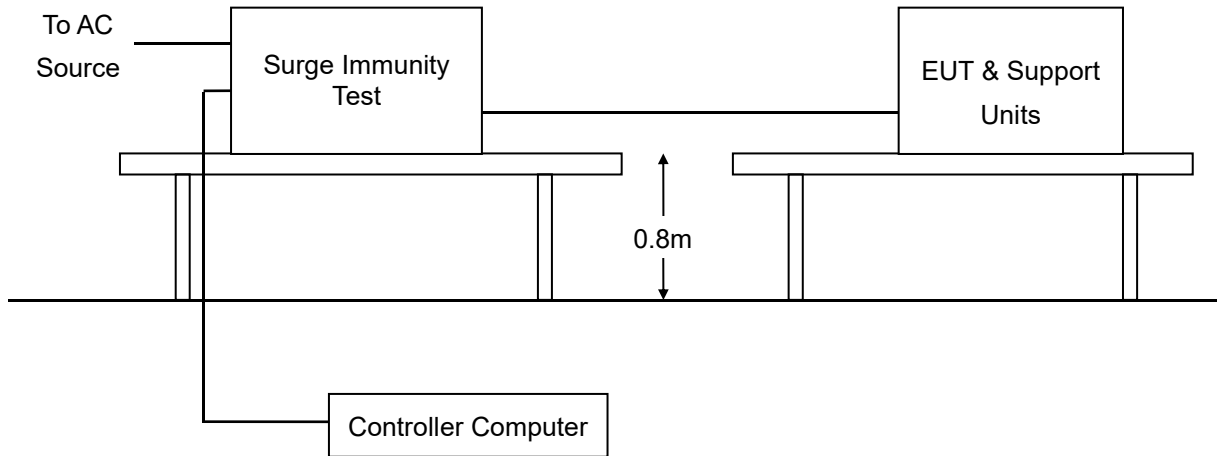

For the actual test configuration, please refer to the related item – Photographs of the Test Configuration.

8.6.4. TEST RESULTS

Temperature (°C)	22~28
Humidity (%RH)	50~54
Barometric Pressure (mbar)	950~1000
EUT	ROOF FANS
M/N	DVR 280T
Operating Mode	Normal Operating
Test Results	Pass

Test Point	Polarity	Test Level (kV)	Performance Criterion	Observation	Result
L - N	+/-	1	B	Note <input checked="" type="checkbox"/> 1 <input type="checkbox"/> 2	PASS
L - PE	+/-	2	B	Note <input checked="" type="checkbox"/> 1 <input type="checkbox"/> 2	PASS
N - PE	+/-	2	B	Note <input checked="" type="checkbox"/> 1 <input type="checkbox"/> 2	PASS
R - Ground	--	--	--	Note <input type="checkbox"/> 1 <input type="checkbox"/> 2	N/A
T - Ground	--	--	--	Note <input type="checkbox"/> 1 <input type="checkbox"/> 2	N/A

NOTE:

1. There was no change compared with initial operation during the test.
2. The loss of function of the EUT during the test and it was recovered by itself operation after the test.

8.7. CONDUCTED RADIO FREQUENCY DISTURBANCES (CS)

8.7.1. TEST SPECIFICATION

Basic Standard: EN 61000-4-6

Frequency Range: 0.15 MHz ~ 230 MHz

Field Strength: 3 V

Modulation: 1kHz Sine Wave, 80%, AM Modulation

Frequency Step: 1 % of preceding frequency value

Coupled cable: Power Mains, Shielded

Coupling device: CDN-M3/2 (2 wires)

Performance criterion: A

8.7.2. TEST PROCEDURE

The EUT shall be tested within its intended operating and climatic conditions.

The test shall be performed with the test generator connected to each of the coupling and decoupling devices in turn, while the other non-excited RF input ports of the coupling devices are terminated by a 50-ohm load resistor.

The frequency range was swept from 150 kHz to 230 MHz, using the signal level established during the setting process and with a disturbance signal of 80 % amplitude. The signal was modulated with a 1 kHz sine wave, pausing to adjust the RF signal level or the switch coupling devices as necessary. The sweep rate was 1.5×10^{-3} decades/s. Where the frequency range is swept incrementally, the step size was 1 % of preceding frequency value from 150 kHz to 230 MHz.

The dwell time at each frequency was less than the time necessary for the EUT to be exercised, and able to respond. Sensitive frequencies such as clock frequency(ies) and harmonics or frequencies of dominant interest, was analyzed separately.

Attempts were made to fully exercise the EUT during testing, and to fully interrogate all exercise modes selected for susceptibility.

8.7.3. TEST SETUP

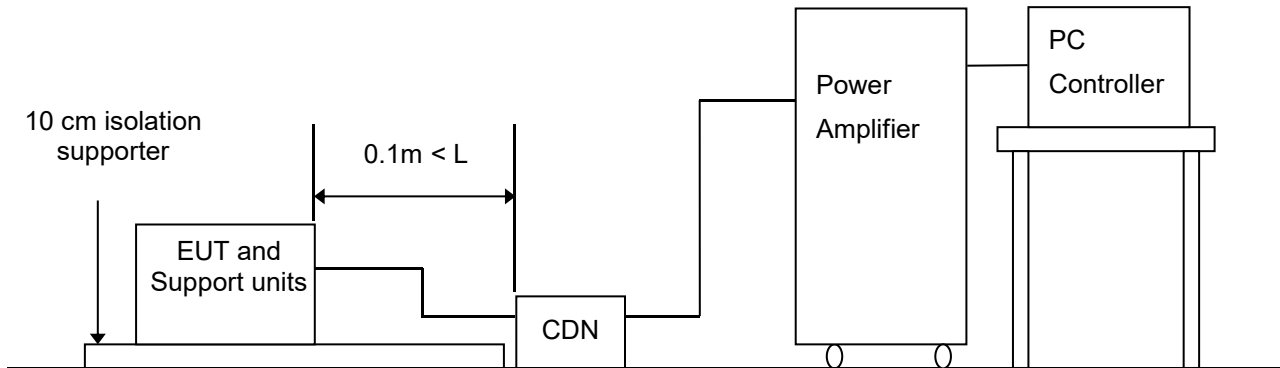

For the actual test configuration, please refer to the related item.

- Note:** 1. The EUT is setup 0.1m above Ground Reference Plane.
 2. The CDNS and / or EM clamp used for real test depends on ports and cables configuration of EUT.

NOTE: TABLE-TOP AND FLOOR-STANDING EQUIPMENT

The equipment to be tested is placed on an insulating support of 0.1 meters height above a ground reference plane. All relevant cables shall be provided with the appropriate coupling and decoupling devices at a distance between 0.1 meters and 0.3 meters from the projected geometry of the EUT on the ground reference plane.

8.7.4. TEST RESULTS

Temperature (°C)	22~28
Humidity (%RH)	50~54
Barometric Pressure (mbar)	950~1000
EUT	ROOF FANS
M/N	DVR 280T
Operating Mode	Normal Operating
Test Results	Pass

Frequency Band (MHz)	Field Strength (Vrms)	Injected Position	Injection Method	Performance Criterion	Observation	Result
0.15 ~ 230	3	AC Mains	CDN-M2	A	Note <input checked="" type="checkbox"/> 1 <input type="checkbox"/> 2	PASS
0.15 ~ 230	3	LAN(10m)	--	--	Note <input type="checkbox"/> 1 <input type="checkbox"/> 2	N/A

NOTE:

1. There was no change compared with initial operation during the test.
2. The loss of function of the EUT during the test and it was recovered by itself operation after the test.
3. N/A means to no applicable.

8.8. POWER FREQUENCY MAGNETIC FIELD (PFMF)

8.8.1. TEST SPECIFICATION

Basic Standard:	EN 61000-4-8
Frequency Range:	50/60Hz
Field Strength:	3A/m
Observation Time:	5 minutes
Inductance Coil:	Rectangular type, 1mx1m
Performance criterion:	N/A

8.8.2. TEST PROCEDURE

- The equipment is configured and connected to satisfy its functional requirements. It shall be placed on the GRP with the interposition of a 0.1m-thick insulating support.
- The equipment cabinets shall be connected to the safety earth directly on the GRP via the earth terminal of the EUT.
- The power supply, input and output circuits shall be connected to the sources of power supply, control and signal.
- The cables supplied or recommended by the equipment manufacturer shall be used. 1 meter of all cables used shall be exposed to the magnetic field.

8.8.3. TEST SETUP

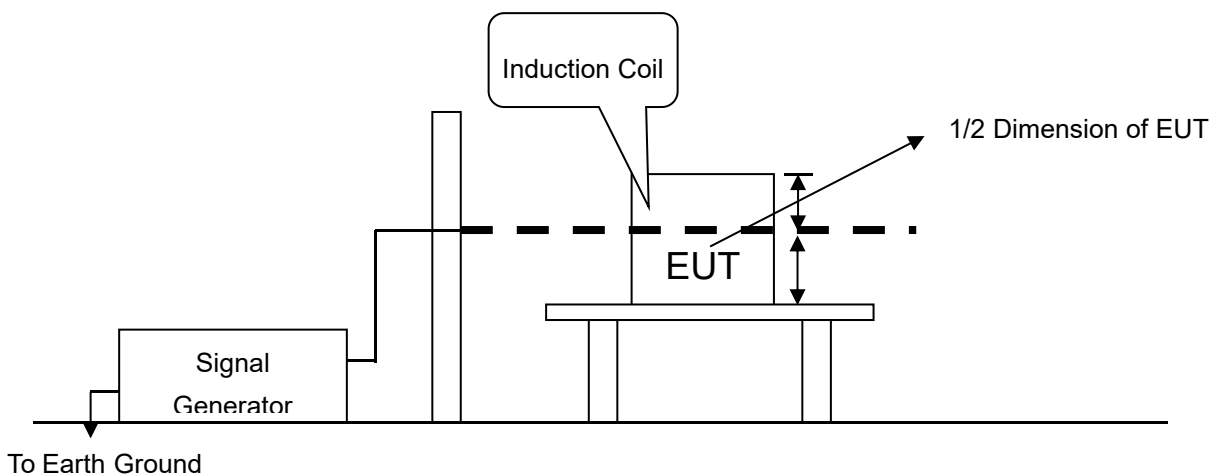

For the actual test configuration, please refer to the related item.

NOTE:
TABLETOP EQUIPMENT

The equipment shall be subjected to the test magnetic field by using the induction coil of standard dimension (1 m x 1 m). The induction coil shall then be rotated by 90 degrees in order to expose the EUT to the test field with different orientations.

FLOOR-STANDING EQUIPMENT

The equipment shall be subjected to the test magnetic field by using induction coils of suitable dimensions. The test shall be repeated by moving and shifting the induction coils, in order to test the whole volume of the EUT for each orthogonal direction. The test shall be repeated with the coil shifted to different positions along the side of the EUT, in steps corresponding to 50 % of the shortest side of the coil. The induction coil shall then be rotated by 90 degrees in order to expose the EUT to the test field with different orientations.

8.8.4. TEST RESULTS

Temperature (°C)	22~28
Humidity (%RH)	50~54
Barometric Pressure (mbar)	950~1000
EUT	ROOF FANS
M/N	DVR 280T
Operating Mode	Normal Operating
Test Results	N/A

8.9. VOLTAGE DIP & VOLTAGE INTERRUPTIONS

8.9.1. TEST SPECIFICATION

Basic Standard: EN 61000-4-11

Test duration time: Minimum three test events in sequence

Interval between event: Minimum 10 seconds

Phase Angle: 0 /45 / 90/ 135/ 180/ 225/ 270/ 315/ 360

Test cycle: 3 times

Performance criterion: B,C

8.9.2. TEST PROCEDURE

1. The EUT and support units were located on a wooden table, 0.8 m away from ground floor.
2. Setting the parameter of tests and then perform the test software of test simulator.
3. Conditions changes to occur at 0 degree crossover point of the voltage waveform.
4. Recording the test result in test record form.

8.9.3. TEST SETUP

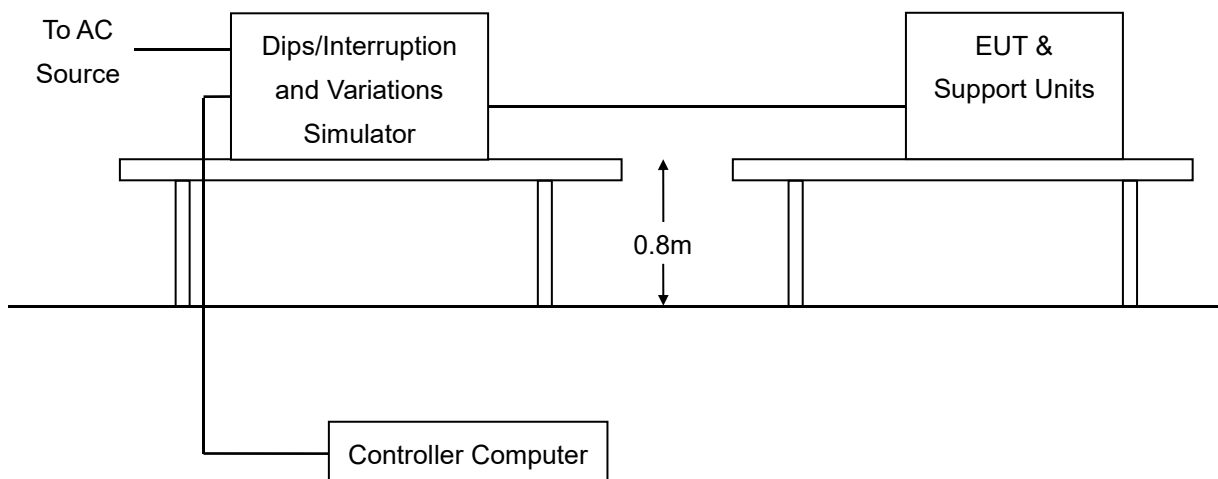

For the actual test configuration, please refer to the related item – Photographs of the Test Configuration.

8.9.4. TEST RESULTS

Temperature (°C)	22~28
Humidity (%RH)	50~54
Barometric Pressure (mbar)	950~1000
EUT	ROOF FANS
M/N	DVR 280T
Operating Mode	Normal Operating
Test Results	Pass

Voltage (% Reduction)	Duration (Period)	Performance Criterion	Observation	Test Result
60	10	<input type="checkbox"/> A <input type="checkbox"/> B <input checked="" type="checkbox"/> C	Note <input type="checkbox"/> 1 <input type="checkbox"/> 2 <input checked="" type="checkbox"/> 3	PASS
30	50	<input type="checkbox"/> A <input type="checkbox"/> B <input checked="" type="checkbox"/> C	Note <input type="checkbox"/> 1 <input type="checkbox"/> 2 <input checked="" type="checkbox"/> 3	PASS
100	0.5	<input type="checkbox"/> A <input type="checkbox"/> B <input checked="" type="checkbox"/> C	Note <input type="checkbox"/> 1 <input type="checkbox"/> 2 <input checked="" type="checkbox"/> 3	PASS

NOTE:

1. There was no change compared with initial operation during and after the test.
No unintentional response was found during the test.
2. The function stopped during the test, but can be recoverable by itself operation after the test.
3. The function stopped during the test, but can be recoverable manually after the test.

9. PHOTOGRAPHS OF EUT

<p>Photo 1</p> <p>View:</p> <p><input checked="" type="checkbox"/> Front</p> <p><input type="checkbox"/> Rear</p> <p><input type="checkbox"/> Right side</p> <p><input type="checkbox"/> Left side</p> <p><input type="checkbox"/> Top</p> <p><input type="checkbox"/> Bottom</p> <p><input type="checkbox"/> Internal</p>	
--	---

<p>Photo 2</p> <p>View:</p> <p><input checked="" type="checkbox"/> Front</p> <p><input type="checkbox"/> Rear</p> <p><input type="checkbox"/> Right side</p> <p><input type="checkbox"/> Left side</p> <p><input type="checkbox"/> Top</p> <p><input type="checkbox"/> Bottom</p> <p><input type="checkbox"/> Internal</p>	
--	--

--END--